

## Switching Structure Based on the MicroStrip Line is Used to Combine High Performance and Cost-effectiveness

- Isolation characteristics of 65 dB or better at 900 MHz
- Effective insertion loss characteristics of 0.2 dB or better at 900 MHz (half the loss of earlier models)
- Fully sealed construction provides excellent environmental resistance.
- Improved shock-resistance (double the resistance of earlier models)

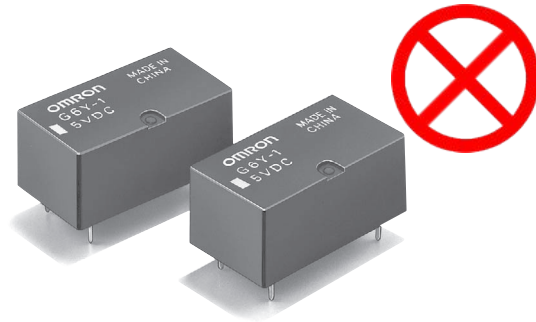

### RoHS Compliant

### Model Number Legend

**G6Y-□□VCD**    1. Number of contact poles  
                   1 2                                    1: Single pole (SPDT contact)

### Standard Specifications

- Contact Mechanism: Double-braking bifurcated contact
- Contact Material: Gold alloy
- Sealing: Fully sealed
- Terminal Configuration: Printed circuit board terminal configuration

### Application Examples

Signal Switching in Various Communications Equipment

- Wired Communications: Cable TV, captain systems, and video response systems (VRS)
- Wireless Communications: Transceivers, ham radio, car telephones, high-level TV, fax machines, satellite broadcasting, text multiplex broadcasting, and pay TV
- Public Equipment: VCRs, TVs, video disk players, and TV games
- Industrial Equipment: Measuring equipment, test equipment, and multiplex transmission devices

### Ordering Information

Classification	Structure Contact form	Fully sealed		Minimum packing unit
		Model	Rated coil voltage	
Basic type	SPDT	G6Y-1	4.5 VDC	100 pcs/tray
			5 VDC	
			9 VDC	
			12 VDC	
			24 VDC	

Note: Please clearly indicate the coil rated voltage (V) when ordering.

Example: G6Y-1 DC4.5

In addition, the delivered product and its package will be marked with voltage specification of □□ VDC.

### Ratings

#### Coil

Classification	Item Rated voltage	Rated current (mA)	Coil resistance (Ω)	Operating voltage (V)	Must release voltage (V)	Max. voltage (V)	Power consumption (mW)
Basic type	4.5 VDC	44.4	101	75% max.	10% min.	150% at 23°C	Approx. 200
	5 VDC	40.0	125				
	9 VDC	22.2	405				
	12 VDC	16.7	720				
	24 VDC	8.3	2,880				

Note 1. The rated current and coil resistance are measured at a coil temperature of 23°C with a tolerance of ±10%.

2. The Operating characteristics are measured at a coil temperature of 23°C.

3. The "Max. allowed voltage" is the maximum voltage that can be applied to the relay coil. It is not the maximum voltage that can be applied continuously.

#### Contacts

Item	Load	Resistive load
Rated load		0.01 A at 30 VAC 0.01 A at 30 VDC 900 MHz, 1 W *
Rated carry current		0.5 A
Max. switching voltage		30 VAC 30 VDC
Max. switching current		0.5 A
Max. switching power (reference value)		AC10VA DC10W

\* This value is for a load with V.SWR x 1.2.

#### High-frequency Characteristics \*1

Item	Frequency	250 MHz	900 MHz	2.5 GHz
Isolation		80 db min.	65 db min.	30 db min.
Insertion loss		0.5 dB max.	0.5 dB max.	-
V.SWR		1.5 max.	1.5 max.	-
Max. carry power		10 W	-	-
Max. switching power		10 W *2	-	-

Note 1. The impedance of the measuring system is 50 Ω.

2. The table above shows preliminary values.

\*1. Contact your Omron representative if the relay will be used in applications that require high repeatability with high-frequency characteristics in microload regions.

\*2. This value is for a load with V.SWR x 1.2.

### Characteristics

Contact resistance *1		100 mΩ max.
Operating time		10 ms max. (approx. 5 ms)
Release time		5 ms max. (approx. 1 ms)
Insulation resistance *2		100 MΩ min.
Dielectric strength	between coil and contacts	1,000 VAC, 50/60 Hz for 1 min
	between contacts of same polarity	500 VAC, 50/60 Hz for 1 min
	between coil and ground and between contacts and ground	500 VAC, 50/60 Hz for 1 min
Vibration resistance	Destruction	10 Hz to 55 to 10 Hz, 0.75-mm single amplitude (1.5 mm double amplitude)
	Malfunction	10 Hz to 55 to 10 Hz, 0.75-mm single amplitude (1.5 mm double amplitude)
Shock resistance	Destruction	1,000 m/s <sup>2</sup>
	Malfunction	500 m/s <sup>2</sup>
Durability	Mechanical	1,000,000 operations min. (at 1,800 operations/hr)
	Electrical	300,000 operations min. (under rated load at 1,800 operations/hr)
Ambient operating temperature		-40°C to 70°C (with no icing)
Ambient operating humidity		5 to 85%
Weight		Approx. 5 g

Note: The table above shows preliminary values.

\*1. Measurement Conditions: 5 VDC, 100 mA, voltage drop method

\*2. Measurement Conditions: Measured at the same points as the dielectric strength using a 500-VDC ohmmeter.

## Engineering Data

### Ambient Temperature vs. Maximum Coil Voltage

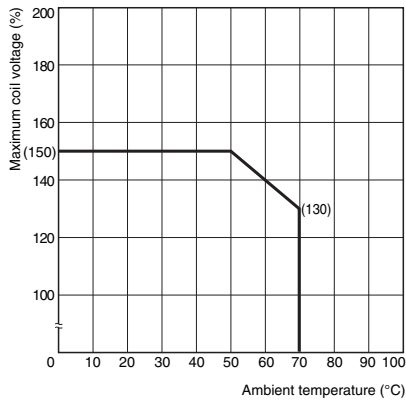

Note: The maximum coil voltage refers to the maximum value in a varying range of operating power voltage, not a continuous voltage.

### Shock Malfunction

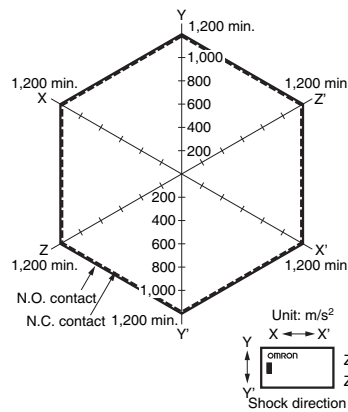

Number of relays: 10 Units  
Conditions: Shock was applied 3 times in each direction with and with out excitation and the level at which the shock caused mal function was measured.  
Rating: 500 m/s<sup>2</sup>

### High-frequency Characteristics

#### Measurement Conditions

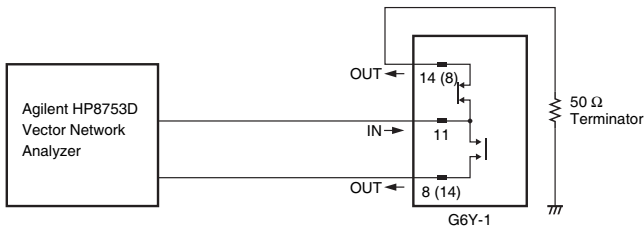

Terminals which were not being measured were terminated with 50 Ω.

Note: The high-frequency characteristics data were measured using a dedicated circuit board and actual values will vary depending on the usage conditions. Check the characteristics of the actual equipment being used.

### Isolation Characteristics (Average Values) \*1, \*2

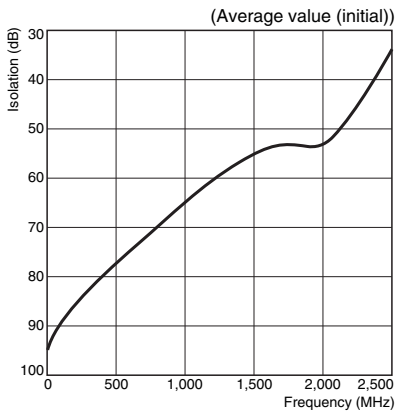

### Insertion Loss Characteristics (Average Values) \*1, \*2.

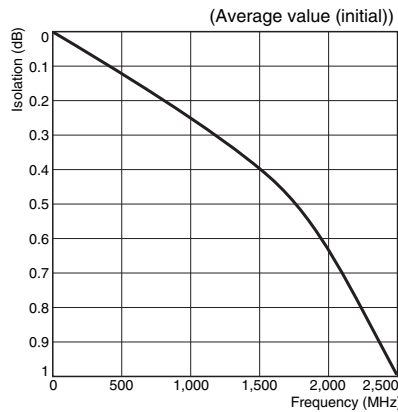

### V.SWR, Return Loss Characteristics (Average Values) \*1, \*2.

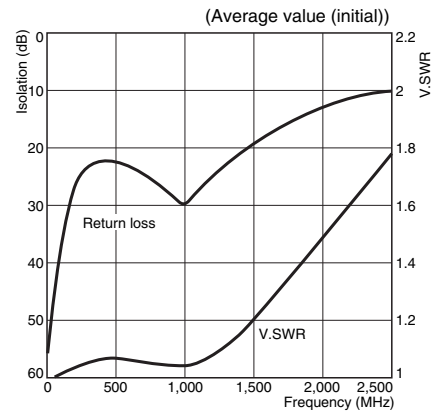

### Operating/Release Time Distribution \*1

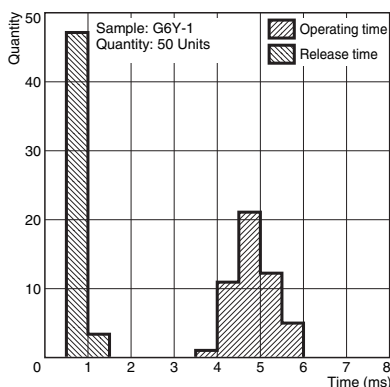

### Bounce Time Distribution \*1

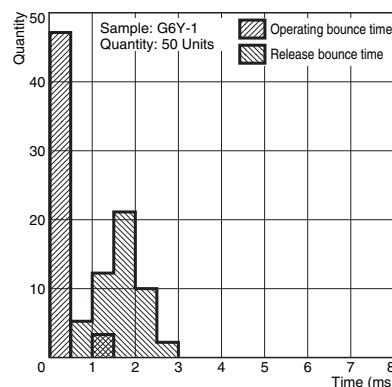

\*1. The tests were conducted at an ambient temperature of 23°C.  
\*2. High-frequency characteristics depend on the PCB to which the Relay is mounted. Always check these characteristics, including endurance, in the actual machine before use.

## Dimensions

G6Y-1

Note: All units are in millimeters unless otherwise indicated.

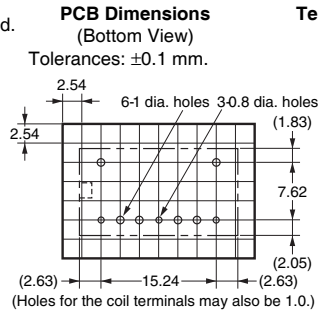
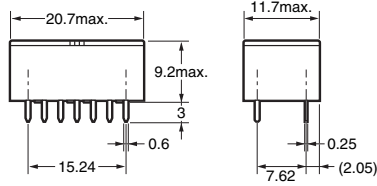
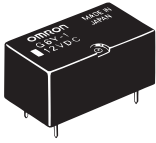

**Terminal Arrangement/Internal Connections (Bottom View)**

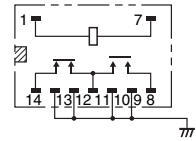

(There is no polarity to the coil.)  
Note: The shaded and unshaded parts indicate the product's directional marks.

## Precautions

● For general precautions on PCB Relays, refer to the precautions provided in General Information of the Relay Product Data Book.

### Correct Use

#### ● Long-term Continuously ON Contacts

- Using the Relay in a circuit where the Relay will be ON continuously for long periods (without switching) can lead to unstable contacts because the heat generated by the coil itself will affect the insulation, causing a film to develop on the contact surfaces. Be sure to use a fail-safe circuit design that provides protection against contact failure or coil burnout. Airtightness when cleaning will last 1 minute at 70°C. Complete cleaning within these conditions.

#### ● Micro Strip Line Design

- It is advantageous to use the Micro Strip Line in high-frequency transmission circuits because a low-loss transmission can be constructed with this method. By etching the dielectric base which has copper foil attached to both sides, the Micro Strip Line will have a concentrated electric field between the lines and ground as shown in the following diagram.

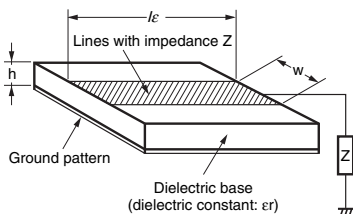

- The characteristic impedance of the lines  $Z_0$  is determined by the kind of base (dielectric constant), the base's thickness, and the width of the lines, as expressed in the following equation.

$$377 / \left( \frac{W}{h} \right) \cdot \sqrt{\epsilon_r} [1 + (1.735\epsilon_r^{-0.0724})$$

$$\left( \frac{W}{h} \right)^{-0.836}]$$

W: Line width

$\epsilon_r$ : Effective dielectric constant

H: Dielectric base thickness

The copper foil thickness must be less than H.

#### ● The following graph shows this relationship.

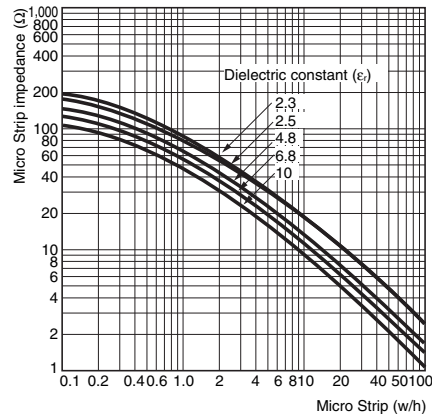

- For example, when creating 50-Ω lines using a glass epoxy base with a thickness of 1.6 mm, the above graph will yield a w/h ratio of 1.7 for a dielectric constant of 4.8. Since the base thickness is 1.6 mm, the width will be  $h \times 1.7 \approx 2.7$  mm. The thickness of the copper foil "t" is ignored in this design method, but it must be considered because large errors will occur in extreme cases such as a foil thickness of  $t \approx w$ . Furthermore, with the Micro Strip Line design, the lines are too short for the G6Y's intended frequency bandwidths, so we can ignore conductive losses and the line's attenuation constant.

- The spacing of the Strip Lines and ground pattern should be comparable to the width of the Strip Lines.
- Design the pattern with the shortest possible distances. Excessive distances will adversely effect the high-frequency characteristics.
- Spread the ground patterns as widely as possible so that potential differences are unlikely to develop between the ground patterns.
- To avoid potential short-circuits, do not place the pattern's leads near the point where the bottom of the Relay attaches to the board.

#### ● Bending the Micro Strip Line

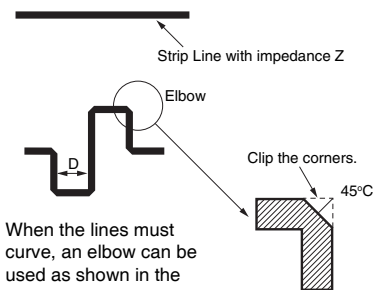

When the lines must curve, an elbow can be used as shown in the diagram. A distance (D) between the lines of approximately twice the line width is sufficient.

#### ● Relay Handling

- When washing the product after soldering the Relay to a PCB, use a water-based solvent or alcohol-based solvent, and keep the solvent temperature to less than 40°C. Do not put the Relay in a cold cleaning bath immediately after soldering.

#### ● Repeatability

- Contact your Omron representative if the relay will be used in applications that require high repeatability with high-frequency characteristics in microload regions.

### Examples of Mounting Designs

- Since this example emphasizes reducing mounting costs, expensive mounting methods such as through-hole boards are not shown. If such methods are to be used, the characteristics must be studied carefully using the actual board configuration.

#### 1. Using a Double-sided Paper Epoxy Board

- When double-sided paper epoxy boards are used, the dielectric constant will be approximately the same as that of glass epoxy boards ( $\epsilon_r=4.8$ ). The width of the Strip Lines for a board with  $t=1.6$  mm is 2.7 mm for 50  $\Omega$  and 1.3 mm for 75  $\Omega$ . For a board with  $t=1.0$  mm the width is 1.7 mm for 50  $\Omega$  and 0.8 mm for 75  $\Omega$ .

- The following diagram shows an example pattern and the Micro Strip Lines connected to the contact terminals are formed with pattern widths derived from the description above. The width between the Micro Strip Lines and ground patterns are comparable to the Micro Strip Line width.

There are jumpers between the upper and lower patterns at the points marked with Xs in the diagram. Improved characteristics can be obtained with more jumper locations. This method yields isolation characteristics of 65 dB to 75 dB at 500 MHz and 50 dB at 900 MHz. At this point in the diagram the component side is the entire ground pattern side, but set aside approximately 2.0 mm  $\times$  2.0 mm of the pattern for the contact terminals and coil terminals.

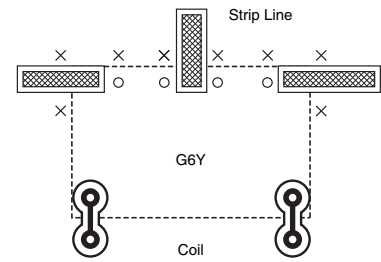

#### 2. Using a Single-sided Board

- When a single-sided board is used, isolation characteristics of only 60 dB to 70 dB at 200 MHz can be obtained. When high frequency bands are to be used with a single-sided board, a metal plate can be placed between the base and Relay and connected to the ground pattern.

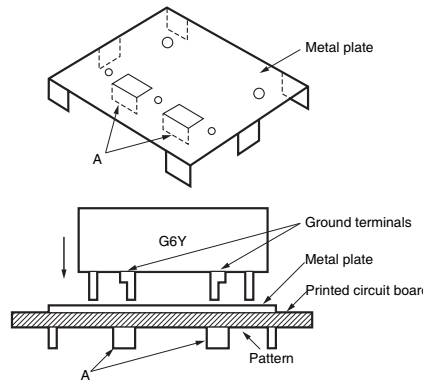

- With this method a metal plate is placed between the Relay and base and connected to the pattern, as shown in the above diagram. The important point here is that 3 locations (the G6Y's ground terminal, the metal plate's bent tabs (A), and the ground pattern) are soldered together at the same time. This method combines an inexpensive single-sided board and inexpensive metal plate to yield the same characteristics as a double-sided board and good characteristics are obtained by grounding the G6Y's ground terminal and metal plate in the same place. The metal plate must be attached to the base as described here. From this point, the methods used for Strip Line design are the same as for the double-sided board.

#### 3. Mounting Precautions

- Be sure to securely attach the Relay's base surface to the board during installation. The isolation characteristics will be affected if the Relay lifts off the board.

- As shown in the enlarged illustration of the cross-section of part A, the G6Y is designed to ensure better high-frequency characteristics if the stand-off part of the G6Y is in contact with the ground pattern of the PCB. Therefore, the ground terminal and stand-off part are electrically connected internally. Should the through hole electrically connected to the contact terminal come in contact with the stand-off part, the contact will be short-circuited with the ground, which may cause in an accident. As a preventive measure, keep at least a distance of 0.3 mm between the stand-off part and the through hole or land. For example, if the terminal hole on the PCB is 1 mm in diameter and the length B shown in the illustration is 1.4 mm, a distance of 0.3 mm or more will be provided between the through hole and stand-off part.

#### PCB Mounting

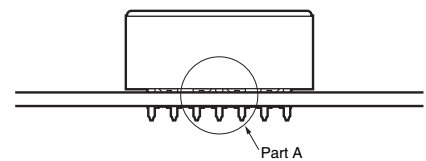

#### Cross-section of Part A

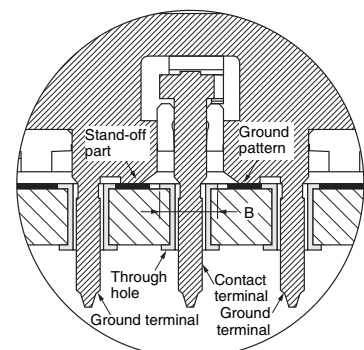

This announcement is based on product catalogue information previously shown before its discontinuation.  
Product information of the existing product may be different from this version.

- Application examples provided in this document are for reference only. In actual applications, confirm equipment functions and safety before using the product.
- Consult your OMRON representative before using the product under conditions which are not described in the manual or applying the product to nuclear control systems, railroad systems, aviation systems, vehicles, combustion systems, medical equipment, amusement machines, safety equipment, and other systems or equipment that may have a serious influence on lives and property if used improperly. Make sure that the ratings and performance characteristics of the product provide a margin of safety for the system or equipment, and be sure to provide the system or equipment with double safety mechanisms.

**Note: Do not use this document to operate the Unit.**