

Compact DPST-NO Door Switch

- Incorporates two circuits for power loads and micro loads. Micro load circuit uses twin contacts.
- Compact size, with an operating force of only 3.24 N {330 gf}.
- Panel- or screw-mounted with ease.

RoHS Compliant

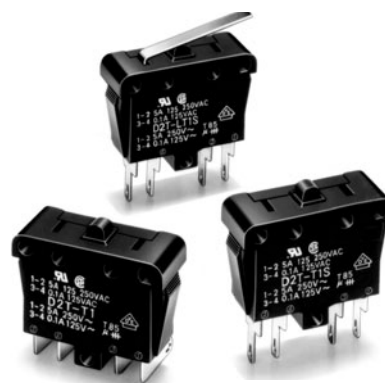

Ordering Information

■ Model Number Legend

D2T- T 1

1 2

1. Actuator

None: Pin plunger



L: Hinge lever

2. Terminals

None: Right-angled solder terminals

S: Straight solder terminals

■ List of Models

Actuator (see note)	Right-angled solder terminals	Straight solder terminals
Pin plunger 	D2T-T1	D2T-T1S
Hinge lever 	D2T-LT1	D2T-LT1S

Note: The actuator of the D2T is identical to that used for OMRON's V Snap-action Switches. The actuator can be replaced with other types of actuators. Consult your OMRON sales representatives for details.

Specifications

■ Ratings

	Rated voltage	Resistive load
Between terminals 1 and 2	250 VAC	5 A
Between terminals 3 and 4	125 VAC	0.1 A

Note: The ratings values apply under the following test conditions:

Ambient temperature: 20±2°C

Ambient humidity: 65±5%

Operating frequency: 30 operations/min

■ Characteristics

Operating speed	10 mm to 500 mm/s (pin plunger models)
Operating frequency	Mechanical: 120 operations/min max. Electrical: 30 operations/min max.
Insulation resistance	100 MΩ min. (at 500 VDC)
Contact resistance (initial value)	Between terminals 1 and 2: 50 mΩ max. Between terminals 3 and 4: 100 mΩ max.
Dielectric strength (see note 2)	1,000 VAC for 1 min 50/60 Hz between terminals of same polarity 1,500 VAC for 1 min 50/60 Hz between current-carrying metal part and ground (see note 1), between each terminal and non-current-carrying metal part, and between terminals of different polarity
Vibration resistance (see note 3)	Malfunction: 10 to 55 Hz, 1.5-mm double amplitude
Shock resistance (see note 3)	Destruction: 1,000 m/s ² {approx. 100G} max. Malfunction: 300 m/s ² {approx. 30G} max.
Durability (see note 4)	Mechanical: 100,000 operations min. (60 operations/min) Electrical: 100,000 operations min. (30 operations/min)
Degree of protection	IEC IP40
Degree of protection against electric shock	Class I
Proof tracking index (PTI)	175
Ambient operating temperature	-25°C to 85°C (at ambient humidity of 60% max.) (with no icing or condensation)
Ambient operating humidity	85% max. (for 5°C to 35°C)
Weight	Approx. 10 g (pin plunger models)

Note: 1. The data given above are initial values.

2. The dielectric strength shown in the table indicates a value for models with a Separator.

3. For the pin plunger models, the above values apply for use at both the free position and total travel position. For the lever models, they apply at the total travel position. Contact opening or closing time is within 1 ms.

4. For testing conditions, consult your OMRON sales representative.

■ Approved Standards

Consult your OMRON sales representative for specific models with standard approvals.

**UL1054 (File No. E41515)/
CSA C22.2 No. 55 (File No. LR21642)**

Rated voltage	Between terminals 1 and 2	Between terminals 3 and 4
125 VAC	5 A	0.1 A (for 100,000 operations)
250 VAC	5 A	---

EN61058-1 (File No. 120144, VDE approval)

Rated voltage	Between terminals 1 and 2	Between terminals 3 and 4
125 VAC	---	0.1 A
250 VAC	5 A	---

Testing conditions: 5E4 (50,000 operations), T85 (0°C to 85°C)

■ Contact Form

DPST-NO

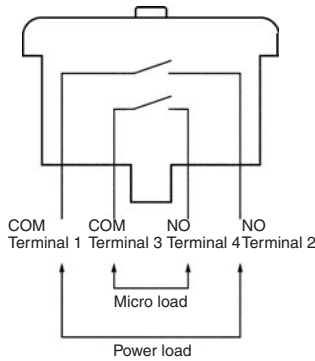

Note: The circuit switching power loads has a snap-action mechanism and the circuit switching micro loads has a slow-action mechanism.

Dimensions

Note: All units are in millimeters unless otherwise indicated.

■ Terminals

Angled Terminals

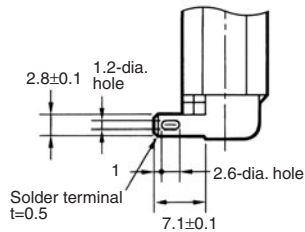

Straight Terminals

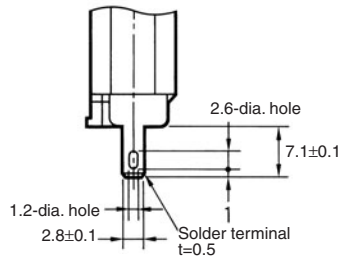

■ Mounting Holes

Panel Cutout Dimensions
(Panel thickness: 1.5 to 2 mm)

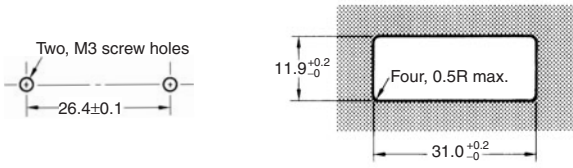

■ Dimensions and Operating Characteristics

- Note:**
1. All units are in millimeters unless otherwise indicated.
 2. Unless otherwise specified, a tolerance of ± 0.4 mm applies to all dimensions.
 3. The following illustrations and dimensions are for D2T models with angled terminals. Refer to the dimensions in *Terminals* for the straight terminals of the D2T.
 4. The operating characteristics are for operation in the A direction (↓).

Pin Plunger Models

D2T-T1
D2T-T1S

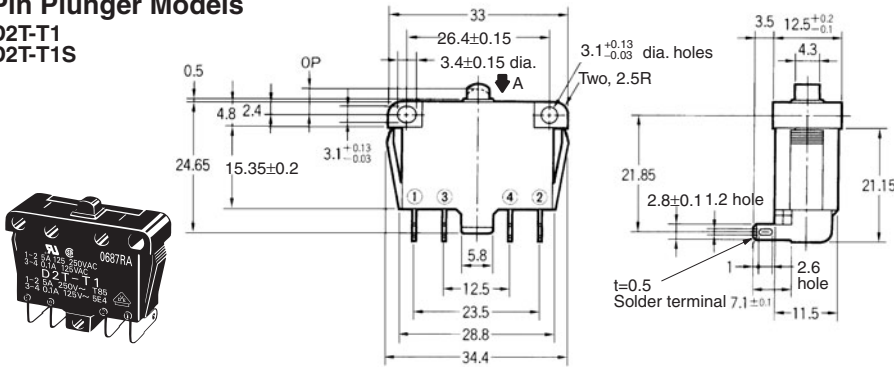

OF max.	3.24 N {330 gf}
RF min.	0.5 N {50 gf}
TTF max.	6.37 N {650 gf}
OT min.	0.8 mm
OP	4.4±0.6 mm (see note)

Note: Operating sequence of the circuit between terminals 1 and 2 and the circuit between terminals 3 and 4 is not specified.

Hinge Lever Models

D2T-LT1
D2T-LT1S

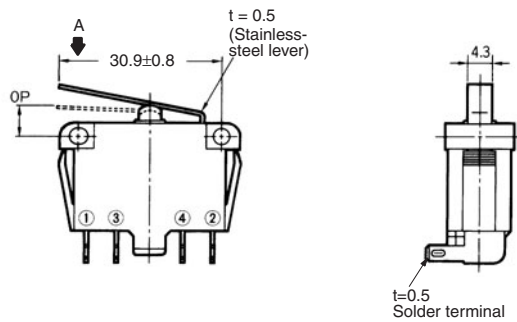
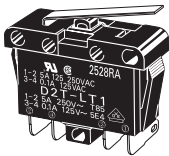

OF max.	1.47N {150gf}
RF min.	0.20N {20gf}
TTF max.	2.45N {250gf}
OT min.	1.6 mm
FP max.	10.1mm
OP	6.9±1.3mm (see note)
RP max.	9.5mm
TTP max.	3.6mm

Note: Operating sequence of the circuit between terminals 1 and 2 and the circuit between terminals 3 and 4 is not specified.

Precautions

Refer to *General Information*.

■ Correct Use

Mounting

Apply operation force to the pin plunger in the direction it operates.

Applying forces laterally or from an oblique direction may damage the pin plunger.

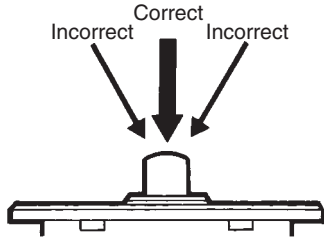

Use M3 mounting screws to mount the Switch. Tighten the screws to a torque of 0.4 to 0.6 N·m {4 to 6 kgf·cm}.

Mounting Holes

When mounting on a metal surface, be sure to provide a Separator between the Switch and mounting plate.

Soldering

When soldering the lead wire to the terminal, first insert the lead wire conductor through the terminal hole and the conduct soldering.

Make sure that the temperature at the tip of soldering iron is 350°C max. Do not take more than 3 seconds to solder the switch terminal, and do not impose external force on the terminal for 1 min after soldering. Improper soldering involving an excessively high temperature or excessive soldering time may deteriorate the characteristics of the Switch.

ALL DIMENSIONS SHOWN ARE IN MILLIMETERS.

To convert millimeters into inches, multiply by 0.03937. To convert grams into ounces, multiply by 0.03527.