

High Reliability for Micro Load Applications, Even in Adverse Atmospheres (Dust, High Humidity, Silicon Gas, Etc.)

- The reed switch offers exceptional contact reliability in micro load applications.
- Same mounting pitch as for the V Miniature Basic Switch.
- Long life expectancy with a bounce time of 1 ms max.

RoHS Compliant



Ordering Information

Model Number Legend

D2RV-
1 2

1. Actuator

- None: Pin plunger
- L11: Short hinge lever
- L: Hinge lever
- L13: Simulated roller lever
- L22: Short hinge roller lever
- L2: Hinge roller lever

2. Maximum Operating Force

- None: 0.49 N {50 gf}
- E: 0.25 N {25 gf}
- G: 0.98 N {100 gf}

Note: These values are for the pin plunger models.

List of Models

Actuator	OF max.	D2RV
Pin plunger	0.25 N {25 gf}	D2RV-E
	0.49 N {50 gf}	D2RV
	0.98 N {100 gf}	D2RV-G
Short hinge lever	0.49 N {50 gf}	D2RV-L11
	0.98 N {100 gf}	D2RV-L11G
Hinge lever	0.25 N {25 gf}	D2RV-L
	0.49 N {50 gf}	D2RV-LG
Simulated roller lever	0.25 N {25 gf}	D2RV-L13
	0.49 N {50 gf}	D2RV-L13G
Short hinge roller lever	0.49 N {50 gf}	D2RV-L22
	0.98 N {100 gf}	D2RV-L22G
Hinge roller lever	0.25 N {25 gf}	D2RV-L2
	0.49 N {50 gf}	D2RV-L2G

Specifications

■ Ratings

Switching voltage	100 VDC max.
Switching current	0.25 A max.
Contact capacity	10 W max.

Note: The values apply under the following test conditions:
 Ambient temperature: 20±2°C
 Ambient humidity: 65±5%
 Operating frequency: 30 operations/min

■ Characteristics

Operating speed	0.1 mm to 1 m/s (pin plunger models)
Operating frequency	Mechanical: 200 operations/min max. Electrical: 200 operations/min max.
Insulation resistance (see note 2)	100 MΩ min. (at 500 VDC)
Contact resistance (initial value)	150 mΩ max.
Dielectric strength	200 VDC for 1 min between terminals of same polarity 500 VAC, 50/60 Hz for 1 min between current-carrying metal parts and ground, and between each terminal and non-current-carrying metal part
Vibration resistance (see note 3)	Malfunction: 10 to 55 Hz, 1.5-mm double amplitude
Shock resistance (see note 3)	Destruction: 500 m/s ² {approx. 50G} max. Malfunction: 200 m/s ² {approx. 20G} max.
Durability (see note 4)	Mechanical: 10,000,000 operations min. (200 operations/min) Electrical: 3,000,000 operations min. (200 operations/min)
Degree of protection	IEC IP40
Degree of protection against electric shock	Class I
Proof tracking index (PTI)	175
Ambient operating temperature	-10°C to 60°C (at ambient humidity of 60% max.) (with no icing or condensation)
Ambient operating humidity	80% max. (for 5°C to 35°C)
Weight	Approx. 7 g (pin plunger models with terminals)

- Note:**
1. The data given above are initial values.
 2. Insulation resistance between terminals of the same polarity is measured at 100 VDC.
 3. For the pin plunger models, the above values apply for use at both the free position and total travel position. For the lever models, they apply at the total travel position.
 4. For testing conditions, contact your OMRON sales representative.

■ Contact Form

SPST-NO

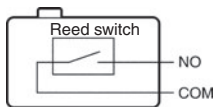

Dimensions

Note: All units are in millimeters unless otherwise indicated.

■ Terminals

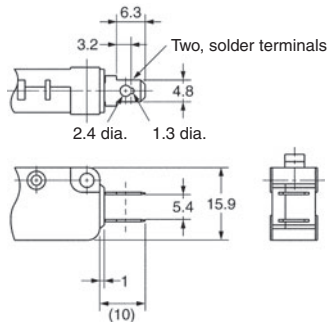

■ Mounting Holes

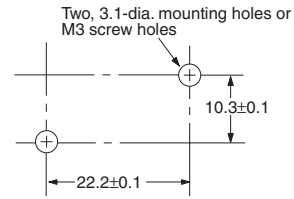

■ Dimensions and Operating Characteristics

- Note:**
1. All units are in millimeters unless otherwise indicated.
 2. Unless otherwise specified, a tolerance of ± 0.4 mm applies to all dimensions.
 3. The □ in the model number is for the OF code.
 4. The operating characteristics are for operation in the A direction (▼).

Pin Plunger Models

D2RV-□

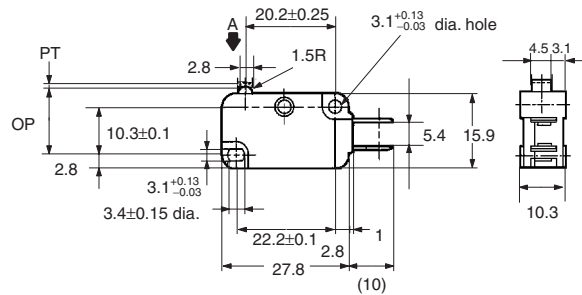
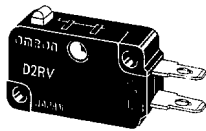

Model	D2RV-E	D2RV	D2RV-G
OF max.	0.25 N {25 gf}	0.49 N {50 gf}	0.98 N {100 gf}
PT max.	1.6 mm		
OT min.	0.6 mm		
MD max.	0.8 mm		
OP	14.4±0.6 mm		

Short Hinge Lever Models

D2RV-L11□

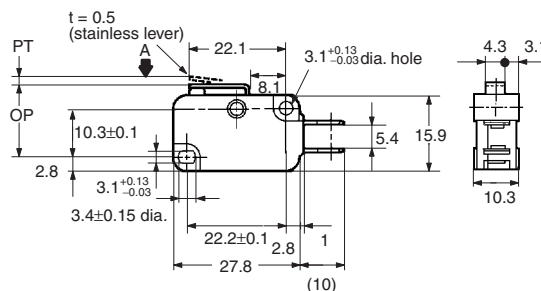
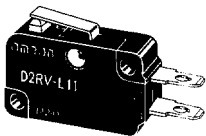

Model	D2RV-L11	D2RV-L11G
OF max.	0.49 N {50 gf}	0.98 N {100 gf}
PT max.	1.8 mm	
OT min.	0.4 mm	
MD max.	1 mm	
OP	15±0.6 mm	

Hinge Lever Models

D2RV-L □

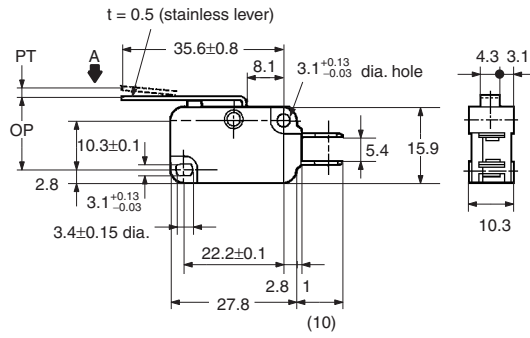
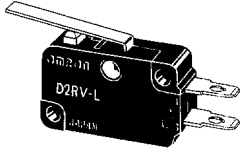

Model	D2RV-L	D2RV-LG
OF max.	0.25 N {25 gf}	0.49 N {50 gf}
PT max.	4 mm	
OT min.	1 mm	
MD max.	1.6 mm	
OP	14.4 ± 1.2 mm	

Simulated Roller Lever Models

D2RV-L13 □

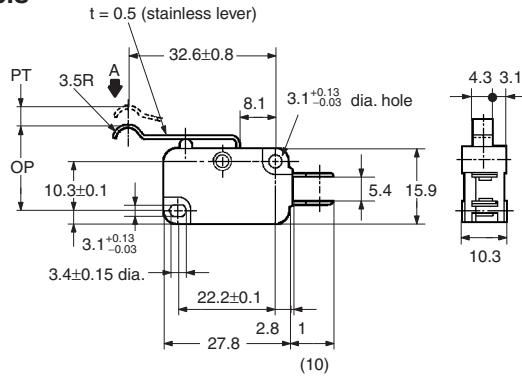
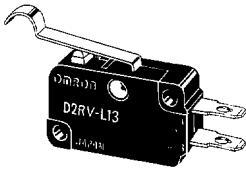

Model	D2RV-L13	D2RV-L13G
OF max.	0.25 N {25 gf}	0.49 N {50 gf}
PT max.	4 mm	
OT min.	1 mm	
MD max.	1.6 mm	
OP	18.1 ± 1.2 mm	

Short Hinge Roller Lever Models

D2RV-L22 □

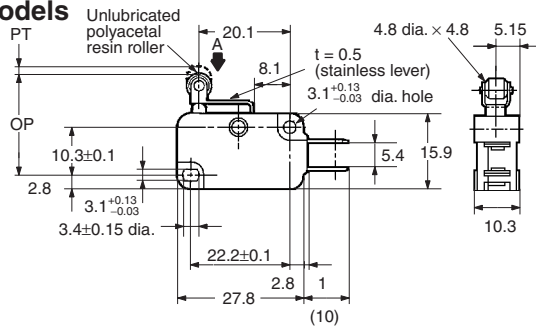
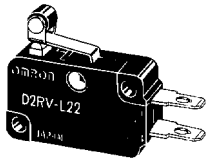

Model	D2RV-L22	D2RV-L22G
OF max.	0.49 N {50 gf}	0.98 N {100 gf}
PT max.	1.8 mm	
OT min.	0.4 mm	
MD max.	1 mm	
OP	20.4 ± 0.6 mm	

Hinge Roller Lever Models

D2RV-L2 □

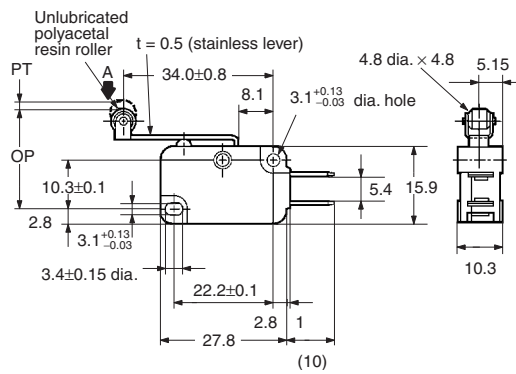
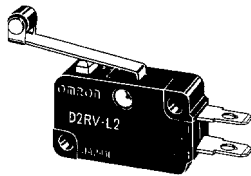

Model	D2RV-L2	D2RV-L2G
OF max.	0.25 N {25 gf}	0.49 N {50 gf}
PT max.	4 mm	
OT min.	1 mm	
MD max.	1.6 mm	
OP	19.9 ± 1.2 mm	

Precautions

Refer to *General Information*.

■ Designing

Contact Protection

Depending on the load, an appropriate protective circuit must be connected across or to the Switch so as to ensure the rated durability of the Switch.

Inductive Load

If the load is inductive, connect a spark killer across the Switch to diminish the spark discharge that may occur when the Switch contacts release.

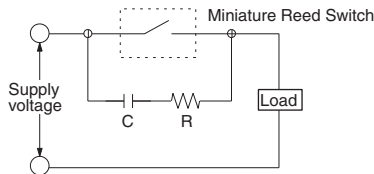

The constants of this spark killer, i.e., resistance R and capacitance C, can be obtained from the graph shown if the following constants are known:

- Load current I
- Load voltage E = EC
- Inductance L

To obtain R, start on the load voltage E axis on the graph. Run up to the point on the axis indicating the given load voltage and then across to the R axis. For example, if E is 24 VDC, R is about 115 Ω.

Next, to determine C, L must be known. Suppose L is 0.5 H, I is 0.5 A, and E is 24 VDC. Then C can be obtained by following these steps:

1. Plot the value of E, 24 V, on the E axis.
2. Plot the point where the EC curve corresponding to E, or the EC = 24 V curve intersects with the value of I, 0.5 A.
3. Join points E and the intersection of EC with I with a straight line. This line is the top dotted line in the graph.
4. Find the point the E-EC line intersects with the value of L, 0.5 H. This intersection indicates the value of 0.14 μF. This is the capacitance the constant C must satisfy.

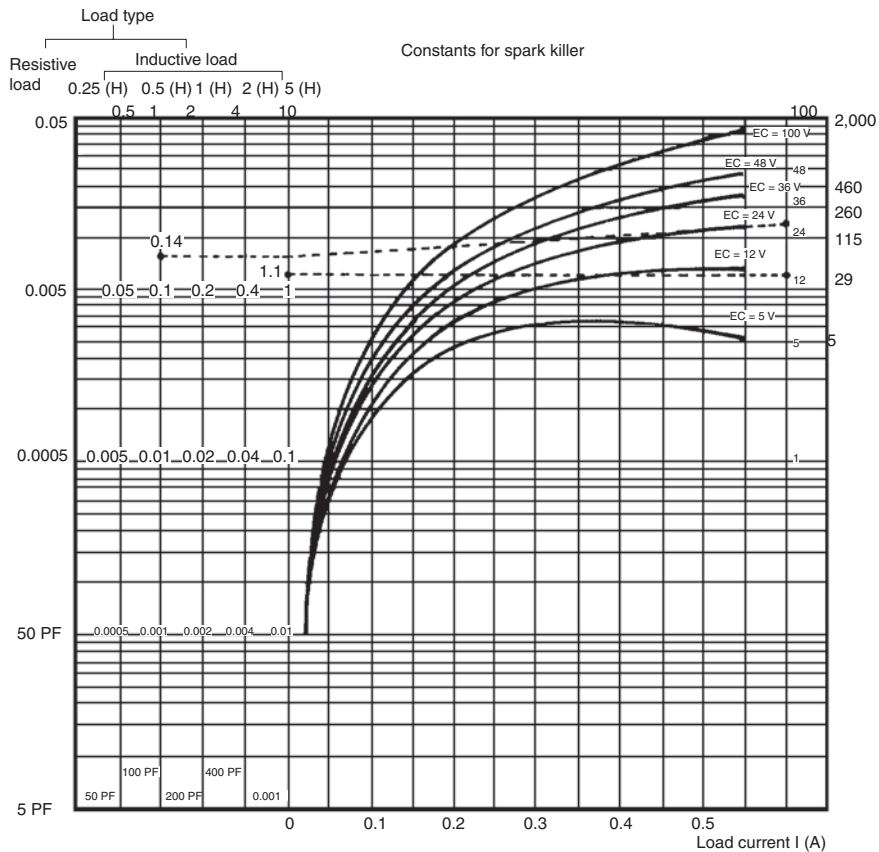

Another Example

For the sake of practice, obtain the value of C where I = 0.4 A, E = 12 VDC, and L = 5 H. The E-EC line in this case is the bottom dotted line on the graph. It indicates the value of 1.1 μF. So, use a capacitor having a capacitance of 1.1 μF.

Example of Other Protective Circuits

For AC circuit load

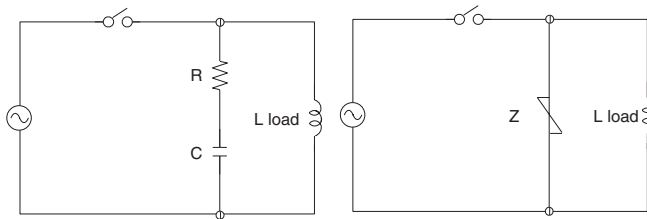

For DC circuit load

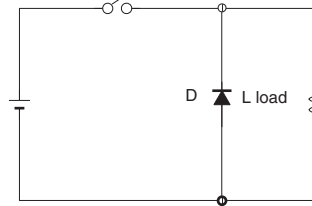

For lamp load

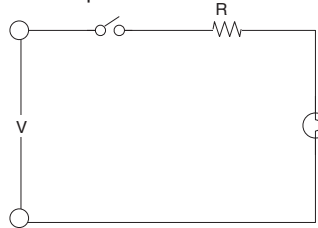

For Electronic Circuit Load

If an electric circuit is connected to the Switch as the load, a high response speed is required from the Switch. To assure the rated response speed of the Switch and to prevent contact bounce, insert an integral circuit between the Switch and the load.

■ Correct Use

Handling

Do not drop the Reed Switch on a hard object such as floor because the internal mechanism of the Switch may be damaged and, as a result, the characteristics of the Switch may be degraded.

Install the Switch so that the actuator can move at least 70% of the rated travel and returns to the free position when the Switch is released.

Take adequate preventive measures against inrush current and surge voltage. Under the load conditions where severe transient phenomena take place, metal deposition may occur between the mating contacts of the Switch, degrading the electrical and mechanical characteristics and contact reliability of the Switch.

Effect of the External Vibration

If a vibration of 1 kHz or higher is added, note that false switching operations may occur due to resonant frequency, even with a low acceleration.

Effect of the External Magnetic Fields

If two or more switch units are closely installed, mutual interference due to the fringing field will occur, resulting in malfunction. Be sure to keep the interval between the switch units 8 mm or more.

Change in Characteristics Due to Temperature Fluctuation

The characteristics of the Switch may be changed with the temperature.

If you install the switch unit on the iron plate, each operating characteristic will change. Therefore, confirm that the interval between the switch units should be 2 mm or more.

Do not use the switch in some area where a strong external magnetic field would be applied, or malfunction will be caused.

Use nonmagnetic brass or stainless steel (SUS304 alloy) screws for installation. Do not use any iron screw.

Lead Wiring

To solder the lead to the terminal, apply a soldering iron rated at 30 W max. quickly (within 5 seconds) with the actuator at the free position.

Applying a soldering iron for too long a time or using one that is rated at more than 30 W may degrade the Switch characteristics.

Mounting

Use two M3 mounting screws with plain or spring washers to mount the Switch. Tighten the screws to a torque of 0.39 N·m {4 to 6 kgf·cm}.

When installing two or more Switches side by side, provide at least 8 mm between the adjacent Switches. If this is impossible, attach the optional magnetic baffle D2RV-□-I to the Switches.

■ Actuator (Sold Separately)

Various Actuators are available as shown on D3V/V/VX/D2MV/D2RV Common Accessories.

■ Connector (Sold Separately)

Refer to Terminal Connectors.

ALL DIMENSIONS SHOWN ARE IN MILLIMETERS.

To convert millimeters into inches, multiply by 0.03937. To convert grams into ounces, multiply by 0.03527.