

Ultra-small and Highly Sealed

- Degree of protection for the molded lead wire models conforms to IEC IP67. (Lead wire type only)
- Wide range of operating temperature from -40°C to 85°C .
- Gold-alloy crossbar contact and coil spring offer long life expectancy and high contact reliability.

RoHS Compliant



Ordering Information

Model Number Legend

D2JW-01 - -

1 2 3

1. Actuator

- None: Pin plunger
- K1A: Short hinge lever
- K1: Hinge lever
- K2: Hinge roller lever
- K3: Simulated roller lever







2. Contact Form

- 1: SPDT
- 2: SPST-NC (Only the models with lead wires)
- 3: SPST-NO (Only the models with lead wires)

3. Terminals

- None: Solder terminals
- MD: Molded lead wires

List of Models

Actuator	Contact form	Model	
		Solder terminals 	Molded lead wires 
Pin plunger 	SPDT	D2JW-011	D2JW-011-MD
	SPST-NC	---	D2JW-012-MD
	SPST-NO	---	D2JW-013-MD
Short hinge lever 	SPDT	D2JW-01K1A1	D2JW-01K1A1-MD
	SPST-NC	---	D2JW-01K1A2-MD
	SPST-NO	---	D2JW-01K1A3-MD
Hinge lever 	SPDT	D2JW-01K11	D2JW-01K11-MD
	SPST-NC	---	D2JW-01K12-MD
	SPST-NO	---	D2JW-01K13-MD
Hinge roller lever 	SPDT	D2JW-01K21	D2JW-01K21-MD
	SPST-NC	---	D2JW-01K22-MD
	SPST-NO	---	D2JW-01K23-MD
Simulated roller lever 	SPDT	D2JW-01K31	D2JW-01K31-MD
	SPST-NC	---	D2JW-01K32-MD
	SPST-NO	---	D2JW-01K33-MD

Note: The standard lengths of the lead wires (AVS0.3f) of models incorporating them are 30 cm.

Specifications

■ Ratings

Electrical ratings	0.1 A at 30 VDC (resistive load)
--------------------	----------------------------------

The ratings values apply under the following test conditions:

Ambient temperature: 20±2°C

Ambient humidity: 65±5%

Operating frequency: 30 operations/min

■ Characteristics

Operating speed (see note 2)	1 mm to 250 mm/s
Operating frequency	Mechanical: 240 operations/min max. Electrical: 30 operations/min max.
Insulation resistance	100 MΩ min. (at 500 VDC)
Contact resistance (initial value)	100 mΩ max. (molded lead wire models: 140 mΩ max.)
Dielectric strength (see note 3)	600 VAC, 50/60 Hz for 1 min between terminals of the same polarity 1,000 VAC, 50/60 Hz for 1 min between current-carrying metal parts and ground, and between each terminal and non-current-carrying metal parts
Vibration resistance (see note 4)	Malfunction: 10 to 55 Hz, 1.5-mm double amplitude
Shock resistance (see note 4)	Destruction: 1,000 m/s ² {approx. 100G} max. Malfunction: 200 m/s ² {approx. 20G} max.
Durability (see note 5)	Mechanical: 1,000,000 operations min. (60 operations/min) Electrical: 100,000 operations min. (30 operations/min)
Degree of protection	IEC IP67 (excluding the terminals on terminal models)
Degree of protection against electric shock	Class I
Proof tracking index (PTI)	175
Ambient operating temperature	-40°C to 85°C (at ambient humidity of 60% max.) (with no icing or condensation)
Ambient operating humidity	35% to 98% (for 5°C to 35°C)
Weight	Approx. 7 g (pin plunger models with molded lead wire models)

- Note:**
1. The data given above are initial values.
 2. The operating speed value shown is for pin plunger models. (For different models, consult your OMRON sales representative.)
 3. The dielectric strength values shown apply for use with Separator (terminal type).
 4. The values shown apply for malfunctions of 1 ms max.
 5. For testing conditions, consult your OMRON sales representative.

■ Contact Specifications

Contact	Specification	Crossbar
	Material	Gold alloy
	Gap (standard value)	0.5 mm
Inrush current	NC	0.1 A max.
	NO	0.1 A max.
Minimum applicable load		1 mA at 5 VDC

■ Contact Form

SPDT

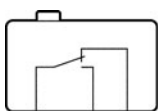

COM (Black*) NO (Blue*) NC (Red*)

SPST-NC

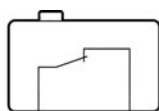

COM (Black) NC (Red)

SPST-NO

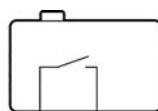

COM (Black) NO (Blue)

*Indicates the color of the lead wire.

Dimensions

Note: All units are in millimeters unless otherwise indicated.

■ Terminals

Solder Terminals

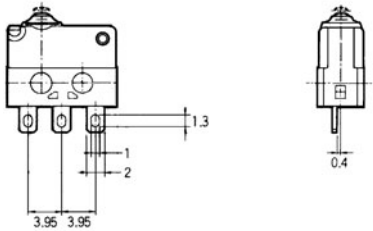

Molded Lead Wires

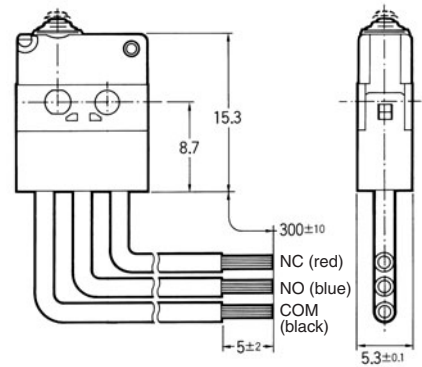

■ Mounting Holes

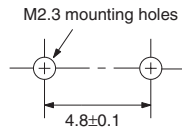

■ Dimensions and Operating Characteristics

- Note:**
- All units are in millimeters unless otherwise indicated.
 - Unless otherwise specified, a tolerance of ± 0.4 mm applies to all dimensions.
 - Actuators of the molded lead wire terminals are omitted here. The dimensions (other than the terminals) and operating characteristics of the molded lead wire terminals are the same as those for the solder terminals.
 - The operating characteristics are for operation in the A direction (↕).

Pin Plunger Models D2JW-011

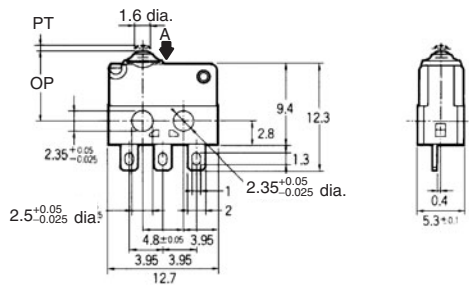

OF max.	2.45 N {250 gf}
RF min.	0.98 N {100 gf}
PT max.	0.6 mm
OT min.	0.3 mm
MD max.	0.1 mm
OP	8.1±0.3 mm

Short Hinge Lever Models D2JW-01K1A1

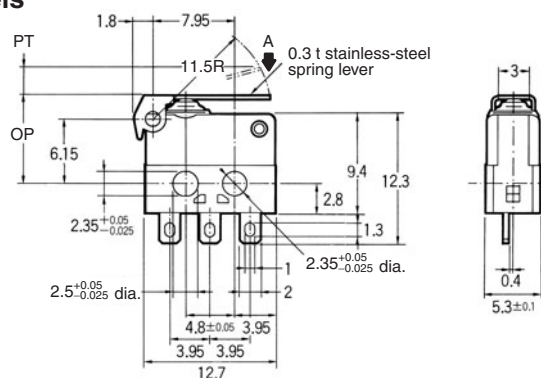

OF max.	1.15 N {117 gf}
RF min.	0.23 N {23 gf}
PT max.	5.4 mm
OT min.	0.7 mm
MD max.	0.5 mm
OP	8.4±0.8 mm

Hinge Lever Models
D2JW-01K11

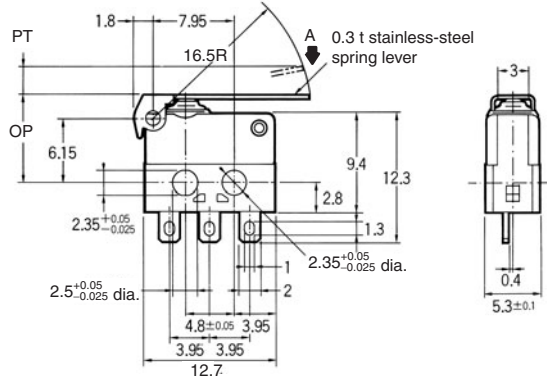

OF max.	0.80 N {82 gf}
RF min.	0.15 N {16 gf}
PT max.	6.4 mm
OT min.	1.4 mm
MD max.	0.7 mm
OP	8.4±0.8 mm

Simulated Roller Lever Models
D2JW-01K31

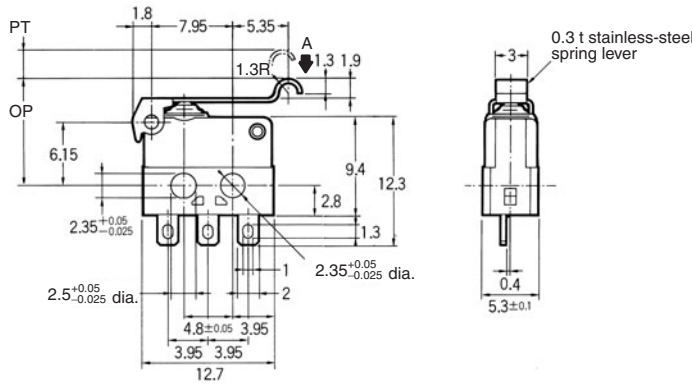

OF max.	0.95 N {97 gf}
RF min.	0.19 N {20 gf}
PT max.	5.5 mm
OT min.	1.1 mm
MD max.	0.6 mm
OP	10.3±0.8 mm

Hinge Roller Lever Models
D2JW-01K21

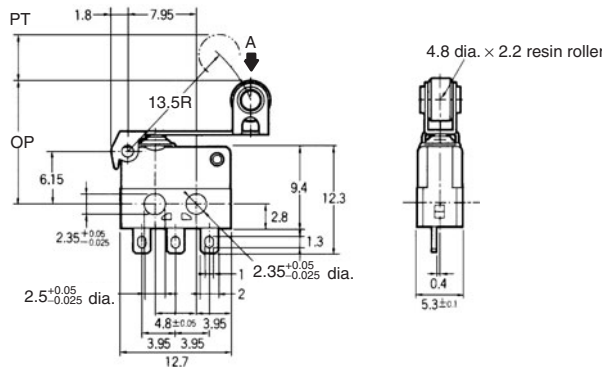

OF max.	0.98 N {100 gf}
RF min.	0.19 N {20 gf}
PT max.	5.2 mm
OT min.	1.1 mm
MD max.	0.5 mm
OP	14.6±0.8 mm

Precautions

Refer to *General Information*.

■ Cautions

Terminal Connection

When soldering, make sure that the capacity of the soldering iron is 30 W maximum (temperature of soldering iron: 250°C max.). Do not take more than 3 s to solder the switch terminal.

If soldering is not carried out under the proper conditions there is a danger of over-heating and subsequent heat damage.

Applying a soldering iron for more than 3 s or using one that is rated at more than 30 W may deteriorate the Switch characteristics.

Degree of Protection

Do not use the Switch underwater. The Switch was tested and found to meet the conditions necessary to meet the following standard. The test checks for water intrusion after immersion for a specified time period. The test does not check for switching operation underwater.

IEC Publication 529, degree of protection IP67.

Protection Against Chemicals

Prevent the Switch from coming into contact with oil and chemicals. Otherwise, damage to or deterioration of Switch materials may result.

■ Correct Use

Use M2.3 mounting screws with plane washers or spring washers to securely mount the Switch. Tighten the screws to a torque of 0.20 to 0.29 N·m {2 to 3 kgf·cm}.

Separator

When mounting the Switch on a metallic surface, be sure to provide a Separator between the Switch and the mounting plate.

■ Separator (Sold Separately)

Model	Separator for D2JW
-------	--------------------

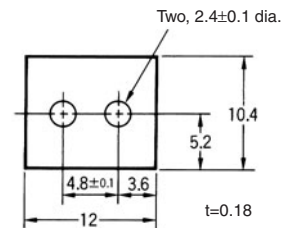

ALL DIMENSIONS SHOWN ARE IN MILLIMETERS.

To convert millimeters into inches, multiply by 0.03937. To convert grams into ounces, multiply by 0.03527.